

ALL
BRITISH
COMPANY

SELF-ADJUSTING ELECTROMAGNETIC CLUTCHES & BRAKES

DATA
SHEET
SIZE
S400

MAXIMUM STATIC TORQUE 23 N.m. 200lb.ins.

The data sheet gives dimensional and technical details for both the Clutch and the Brake. Overall and fixing dimensions are the same for both. The Brake has no inner rotor, this being replaced by a "fixed pole" internally (see drawings overleaf).



Clutch H.P. rating

R.P.M. at Clutch shaft	Allowing for shock torque loads up to 250% of steady load occurring.	
	When load is up to speed	During the accelerating period
	H.P.	H.P.
100	0.128	0.12
200	0.256	0.228
300	0.384	0.33
400	0.512	0.424
500	0.640	0.515
600	0.768	0.6
700	0.896	0.686
800	1.024	0.768
900	1.152	0.854
1000	1.28	0.93
1250	1.6	1.125
1440	1.84	1.25
2000	2.56	1.78
2500	3.18	2.21

General Specification

Maximum Static Torque	: 23 N.m. (200lb.ins.)
Standard Voltage	: 24 Volts D.C.
Rated Continuous Current	: 0.70 amp.
Resistance (20°C)	: 34 Ohms
Other Voltages Available	: 6, 12, 50, 90 Volts D.C.
Maximum Speed	: 6250 R.P.M.
Maximum Heat Dissipation (Slipping)	

At various R.P.M.

0-500 r.p.m.:	2788 Nm/min (2050 ft.lb./min)
1000 r.p.m.:	4250 Nm/min (3125 ft.lb./min)
1500 r.p.m.:	5508 Nm/min (4050 ft.lb./min)
3000 r.p.m.:	7923 Nm/min (5826 ft.lb./min)

Weight : Clutch	: 2.01kg (4lb 7oz)
Brake	: 1.75kg (3lb 14oz)

Torque: Slip characteristic

i.e. Gives torque at moment of engagement and as load is accelerated (Clutch) or decelerated (Brake).

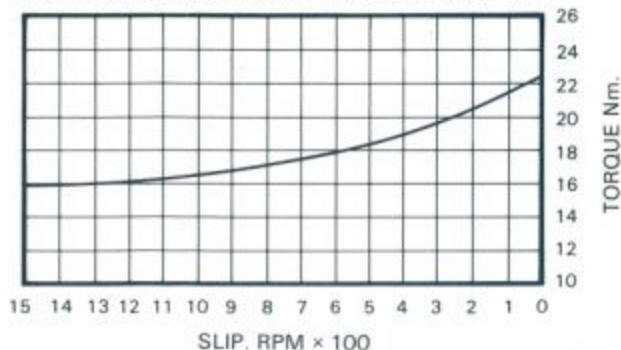

DATA SHEET
SIZE S400

SELF-ADJUSTING ELECTROMAGNETIC CLUTCHES & BRAKES

ALL
BRITISH
COMPANY

To design a satisfactory arrangement, reference should be made to the setting up procedure on the Installation & Maintenance sheet at the front of the catalogue.

CLUTCH

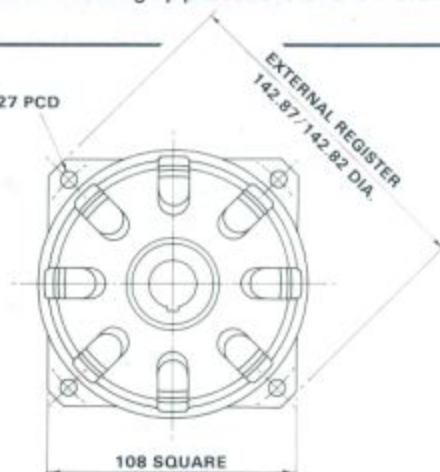
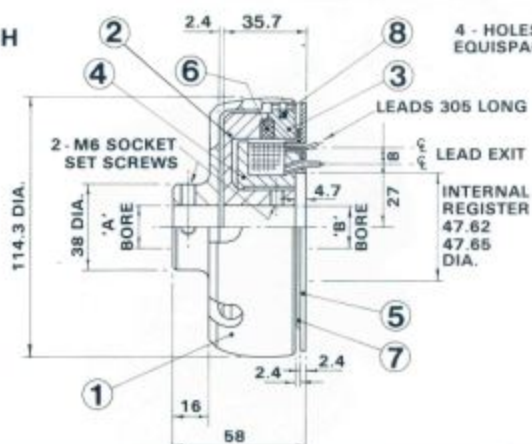

BRAKE

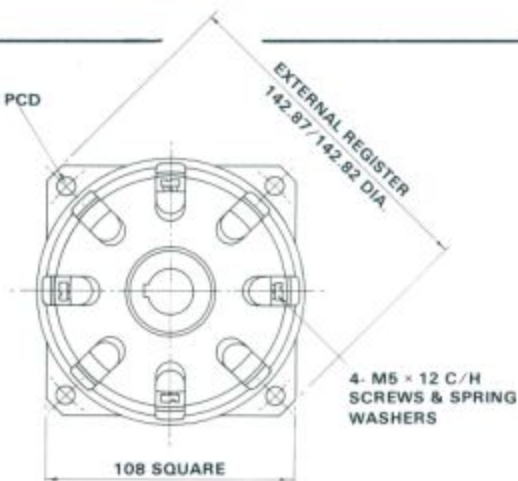
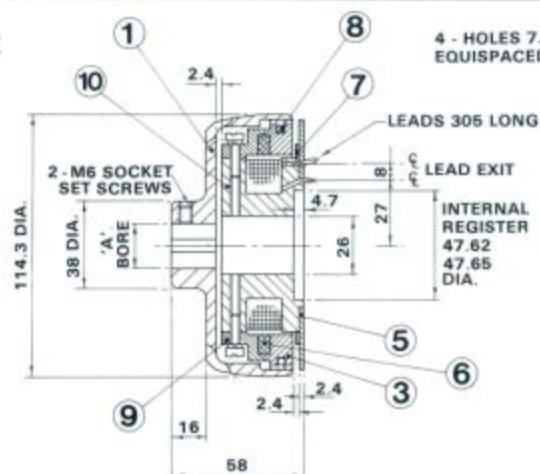

STANDARD BORES

PARTS LIST

ITEM	PART No.	TITLE	No. OFF
1	526	OUTER MEMBER	1
2	527	INNER ROTOR	1
3	4073	DRIVE RING	1
4	530	CLUTCH FIELD SPOOL ASSY	1
5	531	MOUNTING PLATE	1
6	4086	FRICTION RING	1
7	565	MAGNETIC INSULATOR	1
8	733	CUSHION RING	1
9	612	BRAKE FIXED POLE	1
10	613	BRAKE FIELD SPOOL ASSY	1

'A' INCHES	'B' INCHES	KEYWAY WIDTH INCHES
501/500	501/500	1/8
626/625	626/625	3/16
751/750	751/750	1/4
876/875	-	5/16
1001/1000	-	3/8
-0 mm +03	-0 mm +03	mm
11	11	4
12	12	4
14	14	5
15	15	5
16	16	5
17	17	5
19	19	6
20	20	6

CLARK ELECTRIC CLUTCH AND CONTROLS Ltd

28 Victory Park, Trident Close, Medway City Estate, Rochester, Kent, ME2 4ER

Tel.: +44 (0)1634 297408 Fax.: +44 (0)1634 739136 e-mail: sales@clarkelectric.co.uk