

ALL
BRITISH
COMPANY

SELF-ADJUSTING ELECTROMAGNETIC CLUTCHES & BRAKES

DATA
SHEET
SIZE
S250

MAXIMUM STATIC TORQUE 5.7 Nm. 50lb. ins.

The data sheet gives dimensional and technical details for both the Clutch and the Brake. The overall and fixing dimensions are the same for both. The Brake has no inner rotor, this being replaced by a "fixed pole" internally (see drawings overleaf).



Clutch H.P. rating

R.P.M. at Clutch shaft	Allowing for shock torque loads up to 250% of steady load occurring.	
	When load is up to speed	During the accelerating period
	H.P.	H.P.
100	0.032	0.028
200	0.064	0.053
300	0.096	0.076
400	0.128	0.099
500	0.16	0.121
600	0.192	0.14
700	0.224	0.16
800	0.256	0.178
900	0.288	0.197
1000	0.320	0.216
1250	0.4	0.254
1440	0.46	0.292
2000	0.64	0.406
2500	0.8	0.508

General Specification

Maximum Static Torque : 5.7 N.m. (50lb.ins.)
 Standard Voltage : 24 Volts D.C.
 Rated Continuous Current : 0.5 amp.
 Resistance (20°C) : 48 Ohms
 Other Voltages Available : 6, 12, 50, 90 Volts D.C.
 Maximum Speed : 10,800 R.P.M.
 Maximum Heat
 Dissipation (Slipping)

At various R.P.M.

0-500 r.p.m.: 1320 Nm/min (970 ft.lb./min)
 1000 r.p.m.: 2000 Nm/min (1475 ft.lb./min)
 1500 r.p.m.: 2450 Nm/min (1805 ft.lb./min)
 3000 r.p.m.: 3070 Nm/min (2260 ft.lb./min)

Weight : Clutch : 0.62kg (1 lb. 6oz)
 Brake : 0.62kg (1 lb. 6oz)

Torque: Slip characteristic

i.e. Gives torque at moment of engagement
 and as load is accelerated (Clutch) or decelerated (Brake).



DATA
SHEET
SIZE
S250

SELF-ADJUSTING
ELECTROMAGNETIC
**CLUTCHES
& BRAKES**

ALL
BRITISH
COMPANY

To design a satisfactory arrangement, reference should be made to the setting up procedure on the Installation & Maintenance sheet at the front of the catalogue.

CLUTCH

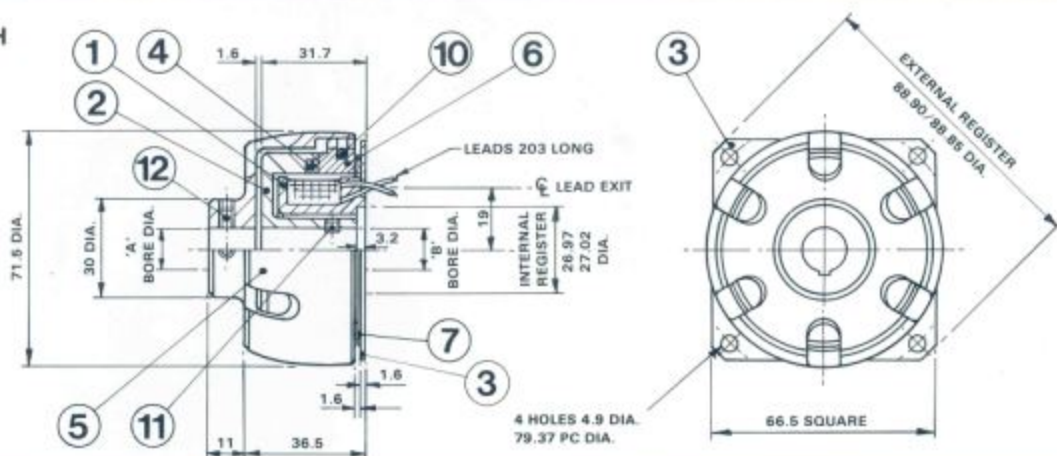

BRAKE

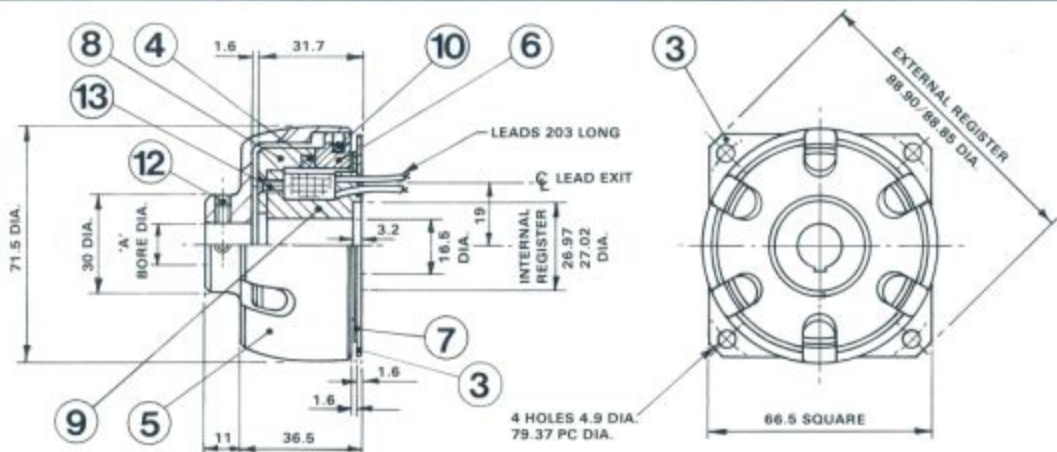

PARTS LIST

ITEM	PART No.	TITLE	No. OFF
1	478	CLUTCH FIELD SPOOL ASSY	1
2	479	INNER ROTOR	1
3	483	MOUNTING PLATE	1
4	5188	FRICTION RING	1
5	490	OUTER MEMBER	1
6	4682	DRIVE RING	1
7	566	MAGNETIC INSULATOR	1
8	5171	BRAKE FIXED POLE	1
9	631	BRAKE FIELD SPOOL ASSY	1
10	734	CUSHION RING	1
11		M3 SOCKET SET SCREW	2
12		M4 SOCKET SET SCREW	2
13		M4 CSK. SOCKET SCREW	3

STANDARD BORES

'A' INCHES	'B' INCHES	KEYWAY WIDTH INCHES
3125/3135	3125/3135	1/8
375/376	375/376	1/8
4375/4385	4375/4385	3/8
500/501	500/501	1/2
625/626	-	5/8
750/751	-	3/4
-0	-0	
mm +03	mm +03	mm
8	8	2
9	9	3
10	10	3
11	11	4
12	12	4
14	14	5

CLARK ELECTRIC CLUTCH AND CONTROLS Ltd

28 Victory Park, Trident Close, Medway City Estate, Rochester, Kent, ME2 4ER
Tel.: +44 (0)1634 297408 Fax.: +44 (0)1634 739136 e-mail: sales@clarkelectric.co.uk