

ALL
BRITISH
COMPANY

ASSEMBLY AND MAINTENANCE INSTRUCTIONS FOR CLUTCHES & BRAKES

MAINTENANCE
SHEET
SIZES
S175
S250
S400

The S type clutch is designed for use where a support already exists for the coil assembly, i.e. where a shaft emerges from the side frame of a machine or casting. The face to which the field spool is to be secured should be machined and equipped with a spigot or recess to suit either the internal or external registers provided on the field spool assembly.

Clutch and Brake Concentric Mounting of Coil Assembly

(a) Using External Register

The corners of the square mounting plate are turned concentrically with the bore and may be located in a recess in the support plate where this is convenient - diagram (a)

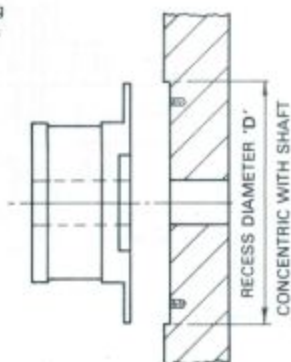

Diagram (a)

Size	'D'
1.75	61.92 61.97
2.50	88.92 88.97
4.00	142.90 142.95

(b) Using Internal Register

Alternatively, the counterbore in the coil assembly may be located on the flange of an 'OILITE' washer or flanged 'OILITE' bush which may also function as a shaft bearing - diagram (b).

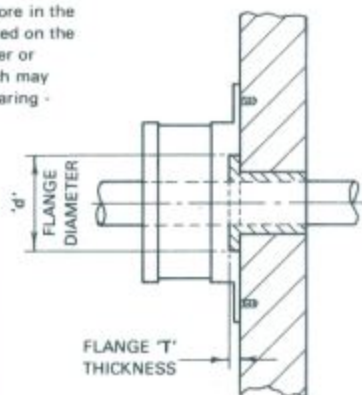

Diagram (b)

Size	'd'	'T'
1.75	19.03 19.01	3.94 3.96
2.50	26.95 26.93	3.15 3.17
4.00	47.60 47.57	4.51 4.53

Clutch Shaft Alignment Requirements

The 2 shafts between which the clutch is to be mounted, should be rigidly supported within the given requirement of alignment, as shown in the table - Setting up Alignment.

The shafts should be keywayed to suit both inner rotor and outer member bores.

The key need not be full length in inner rotor. For ease of removal dimple shafts where grub screws are used for axial positioning.

Where these requirements for rigidity and alignment cannot be met, use should be made of the BM EH type clutch or the clutchbrake unit. See relevant Data Sheets.

Setting Up Alignment	Size	Total Indicated Reading
Parallel alignment between shafts should be within :	1.75	0.13 (.005")
	2.50	
	4.00	
Angular alignment between shafts and squareness of shaft to support plate should be within :	1.75	0.13 (.005") measured at 27 dia. 0.13 (.005") measured at 45 dia. 0.13 (.005") measured at 76 dia.
	2.50	
	4.00	

Assembly of Clutch Inner Rotor, Drive Ring and Friction Ring Diagram (c)

(a) Fix field spool to support.

(b) Place drive ring (with neoprene cushion ring in groove) and friction ring over the spool.

(c) (i) If the shaft can be pushed temporarily to project beyond spool end; fix the inner rotor to the shaft with the two grub screws and a key and then return the shaft with inner rotor into the spool. Locate the shaft axially so as to give correct dimension 'X' (diagram (d)).

(ii) If the shaft is axially fixed and cannot be pushed through spool; remove the two grub screws from the inner rotor and fit it to the shaft with a key and LOCTITE ('Bearing fit' grade). Check dimension 'X'.

(d) Note the axial position of the inner rotor is correct when the end is flush with the bottom of the coil recess and could bear on the flange of the bearing.

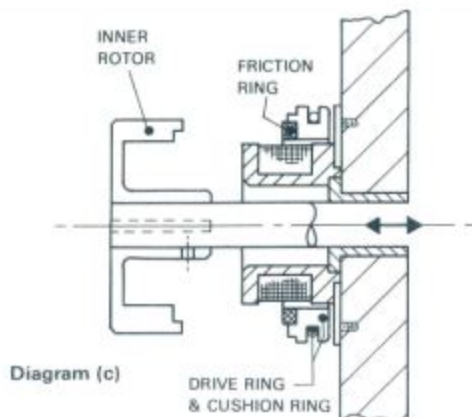

Diagram (c)

MAINTENANCE
SHEET
SIZES
S175
S250
S400

ASSEMBLY AND MAINTENANCE INSTRUCTIONS FOR CLUTCHES & BRAKES

ALL
BRITISH
COMPANY

Brake Assembly (continued)

The brake has no inner rotor and the outer member should be fitted to the shaft and assembled as described in the next section.

The shaft in the case of a brake will usually pass right through the spool. Ensure clearance 'Z' is maintained.

Clutch and Brake Assembly of Outer Member

Diagram (d)

Place the outer member over the other shaft and key and then locate the internal teeth over the drive ring teeth and cushion ring. Set the outer member to give clearance 'Z' and tighten the grub screws. At this stage check operation by applying DC to the coil. For the very first engagement only it may be necessary to lever the drive ring into the outer member with a thin screwdriver blade from behind until it snaps home magnetically. Full torque will develop after a number of running engagements.

Size	'X'	'Z'
1.75	23.8	1.6
2.50	31.7	1.6
4.00	35.7	2.4

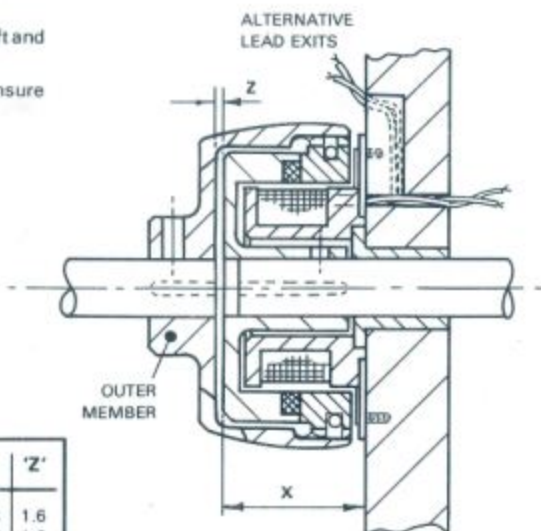

Diagram (d)

Friction Rings and Pole Faces

Diagram (e)

When a unit is new the pole faces touch without clamping the friction ring. **ON NO ACCOUNT SHOULD THE POLE FACES BE MACHINED SINCE THE CLUTCH OR BRAKE WILL NOT OPERATE WITH ANY GAP BETWEEN THE POLE FACES.**

In use the Pole Faces wear down and after a period of use the torque is transmitted simultaneously across the pole faces and the friction ring. After some time the surfaces will exhibit a black dust coating; this is not detrimental and should be left undisturbed.

It is important to ensure that no oil or grease is allowed to come into contact with the friction ring or enter the flutes of the outer member, at any stage of assembly or operation. The spline teeth on the drive ring and outer member should be left dry.

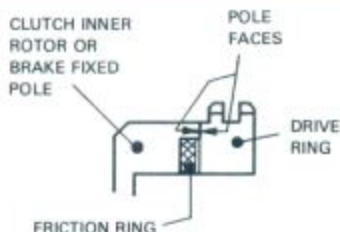

Diagram (e)

Automatic Wear Compensation

In normal use the clutches and brakes require no maintenance since compensation for friction ring wear is taken up automatically. When replacement of worn parts becomes necessary spare kits are available. It is essential that spares are fitted as a set; new parts must not be mixed with worn parts.

Clutch spares kit comprises : Inner rotor, (state bore diameter), friction ring, drive ring, cushion ring.

Brake spares kit comprises : Brake fixed pole, friction ring, drive ring cushion ring.

Bedding In

Where it is known that the Clutch and Brake are to be used on low speed applications, the unit may be supplied bedded-in in order that full torque will be available after a few operations.

On fast speed applications, the units will develop full torque after a few operations.

Electrical Note :

If not using a Clark Power Unit, always connect a 0.22 mfd 1000v. capacitor permanently across the clutch or brake coil to protect the control switch contacts.

CLARK ELECTRIC CLUTCH AND CONTROLS Ltd

28 Victory Park, Trident Close, Medway City Estate, Rochester, Kent, ME2 4ER

Tel.: +44 (0)1634 297408 Fax.: +44 (0)1634 739136 e-mail: sales@clarkelectric.co.uk