

CLARK *ELECTRIC CLUTCH*

FAIL SAFE BRAKES

DATA SHEET

TYPE	FS/1
MODEL	FS 60/1
Cat Nos	24031 & 32

CLARK ELECTRIC CLUTCH TYPE FS/1 FAIL SAFE BRAKES are multi-spring operated electromagnetically released. They are engineered to a very high standard for incorporation into the highest quality machines. They feature a provision for checking and adjusting for wear without dismantling.



Cat No 24031 Type FS 60/1S Standard Hub



Cat No 24032 Type FS 60/1L Long Hub

Type FS/1 Brakes may be used in both dynamic braking and holding applications. The constructional principles are shown in this diagram.

The rotationally fixed armature is pressed into contact with the rotor plate by means of a number of springs. The rotor plate carries generously proportioned friction linings for a very long life and minimum adjustment. When adjustment is eventually necessary, it may be made in increments of 0.1mm by turning the brake shell round to the next notch. The locking screw secures the shell in position. This feature enables rate of wear in any application to be measured. To facilitate access the locking screw has alternative positions. Release of the brake is effected by the field body pulling the armature back against the spring pressure when the field is energised. The rotor plate may then rotate freely. Hub selection is determined by the design of machine shaft.

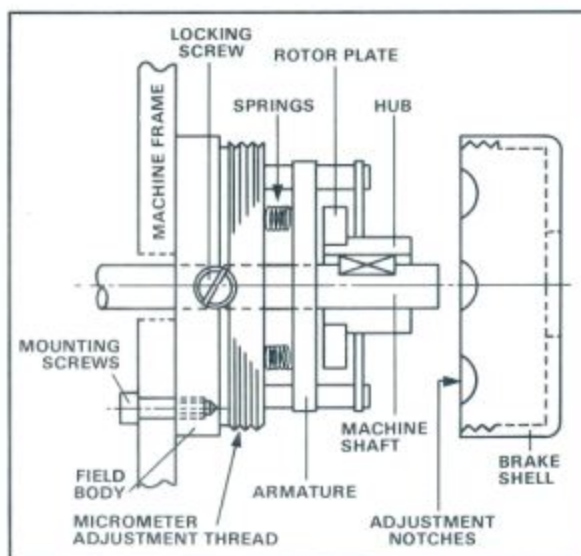

GENERAL SPECIFICATION Model FS 60/1

BRAKING TORQUES:

Static Holding Torque
Dynamic Braking Torque

Nm	kg cm	lb ins
2	20	17
1.5	15	13

Average Brake Disengagement time 35 m secs
Average Brake Engagement time 20 m secs
Weight 0.6 kg

Standard Coil Voltage 24 DC
Disengage Current (Continuous rated at 20°C) 0.5 amp
Electrical Power Consumption at 24 volts 12 watts
Coil Resistance (20°C) 48 ohms

Other models in the FS/1 series of fail safe brakes are available from 80 to 140mm diameters having braking torques 4-30 Nm.

Clark Electric Clutch also produces a complete range of electromagnetically engaged clutches and brakes from 25 to 200mm diameter with all associated power supply units and controls.

INSTALLATION DIMENSIONS

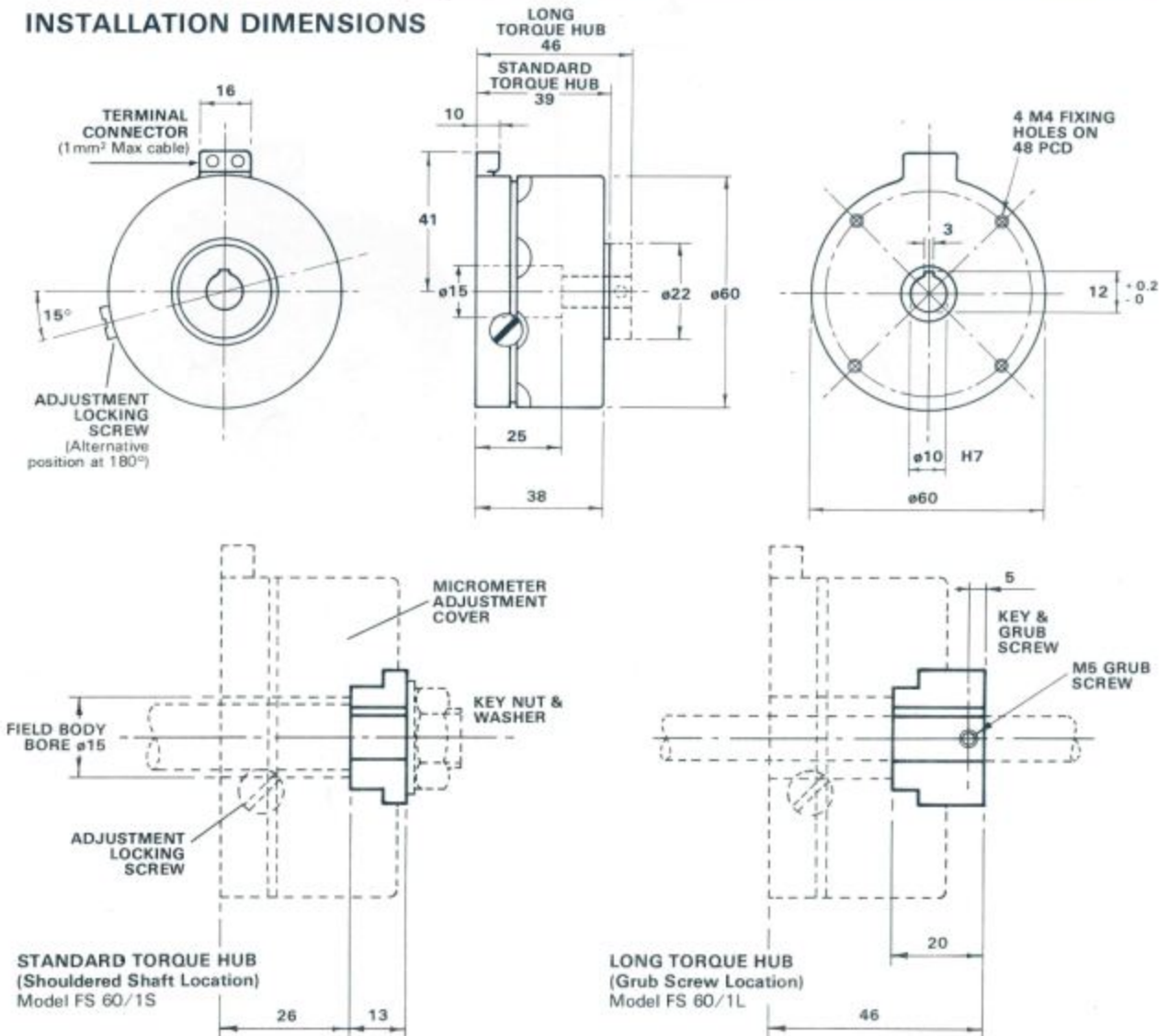

CLARK ELECTRIC CLUTCH AND CONTROLS Ltd

28 Victory Park, Trident Close, Medway City Estate, Rochester, Kent, ME2 4ER
Tel.: +44 (0)1634 297408 Fax.: +44 (0)1634 739136 e-mail: sales@clarkelectric.co.uk

CLARK *ELECTRIC CLUTCH* *FAIL SAFE BRAKES*

DATA SHEET

TYPE	FS/1
MODEL	FS 80/1
Cat Nos	24033 & 4

CLARK ELECTRIC CLUTCH TYPE FS/1 FAIL SAFE BRAKES are multi-spring operated electromagnetically released. They are engineered to a very high standard for incorporation into the highest quality machines. They feature a provision for checking and adjusting for wear without dismantling.



Cat No 24033 Type FS 80/1S Standard Hub



Cat No 24034 Type FS 80/1L Long Hub

Type FS/1 Brakes may be used in both dynamic braking and holding applications. The constructional principles are shown in this diagram.

The rotationally fixed armature is pressed into contact with the rotor plate by means of a number of springs. The rotor plate carries generously proportioned friction linings for a very long life and minimum adjustment. When adjustment is eventually necessary, it may be made in increments of 0.1mm by turning the brake shell round to the next notch. The locking screw secures the shell in position. This feature enables rate of wear in any application to be measured. To facilitate access the locking screw has alternative positions. Release of the brake is effected by the field body pulling the armature back against the spring pressure when the field is energised. The rotor plate may then rotate freely. Hub selection is determined by the design of machine shaft.

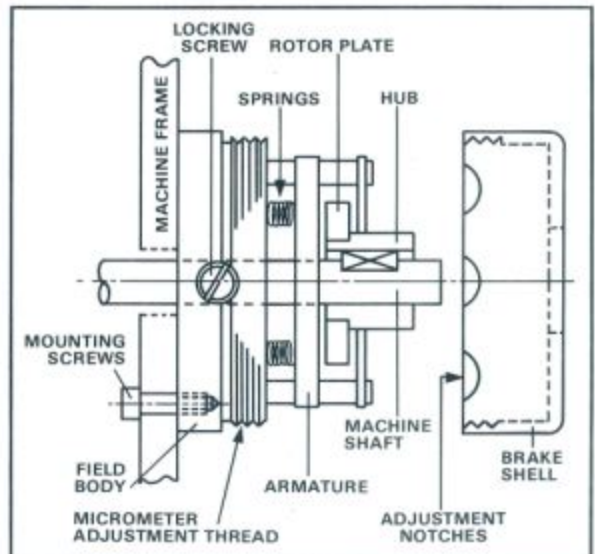

GENERAL SPECIFICATION Model FS 80/1

BRAKING TORQUES:

Static Holding Torque
Dynamic Braking Torque

Nm	kg cm	lb ins
5.5	56	48
4	40	35

Average Brake Disengagement time 35 m secs
Average Brake Engagement time 20 m secs
Weight 1.2 kg

Standard Coil Voltage 24 DC
Disengage Current (Continuous rated at 20°C) 0.55 amp
Electrical Power Consumption at 24 volts 13.2 watts
Coil Resistance (20°C) 44 ohms

Other models in the FS/1 series of fail safe brakes are available from 60 to 140mm diameters having braking torques 2-30 Nm.

Clark Electric Clutch also produces a complete range of electromagnetically engaged clutches and brakes from 25 to 200mm diameter with all associated power supply units and controls.

INSTALLATION DIMENSIONS

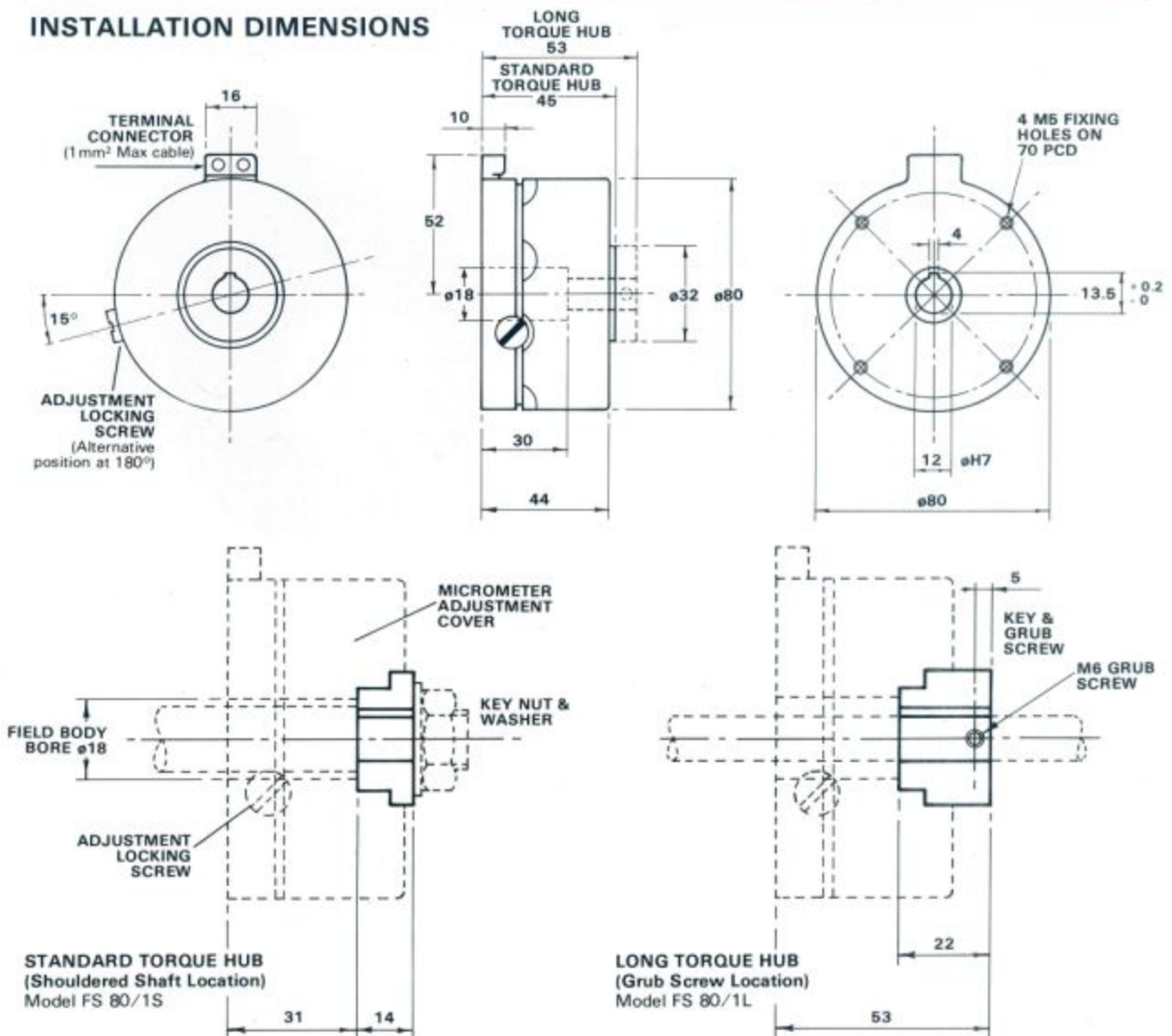

CLARK ELECTRIC CLUTCH AND CONTROLS Ltd

28 Victory Park, Trident Close, Medway City Estate, Rochester, Kent, ME2 4ER
Tel.: +44 (0)1634 297408 Fax.: +44 (0)1634 739136 e-mail: sales@clarkelectric.co.uk

CLARK *ELECTRIC* *CLUTCH*

FAIL SAFE BRAKES

DATA SHEET

TYPE	FS/1
MODEL	FS 100/1
Cat Nos	24035 & 36

CLARK ELECTRIC CLUTCH TYPE FS/1 FAIL SAFE BRAKES are multi-spring operated electromagnetically released. They are engineered to a very high standard for incorporation into the highest quality machines. They feature a provision for checking and adjusting for wear without dismantling.



Cat No 24035 Type FS 100/1S Standard Hub

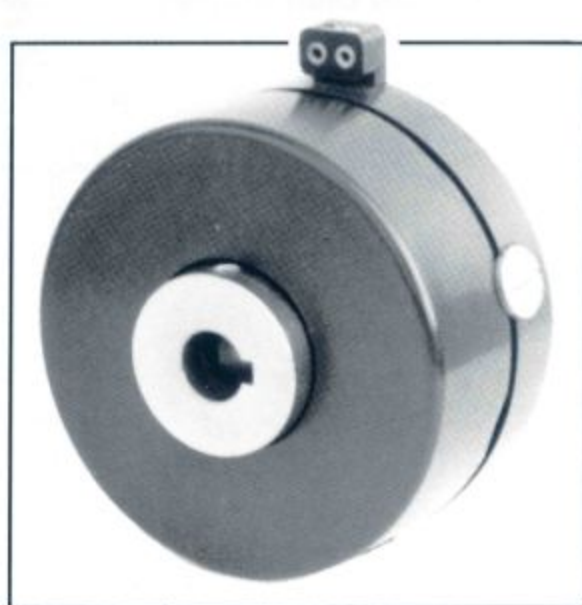

Cat No 24036 Type FS 100/1L Long Hub

Type FS/1 Brakes may be used in both dynamic braking and holding applications. The constructional principles are shown in this diagram.

The rotationally fixed armature is pressed into contact with the rotor plate by means of a number of springs. The rotor plate carries generously proportioned friction linings for a very long life and minimum adjustment. When adjustment is eventually necessary, it may be made in increments of 0.1mm by turning the brake shell round to the next notch. The locking screw secures the shell in position. This feature enables rate of wear in any application to be measured. To facilitate access the locking screw has alternative positions. Release of the brake is effected by the field body pulling the armature back against the spring pressure when the field is energised. The rotor plate may then rotate freely. Hub selection is determined by the design of machine shaft.

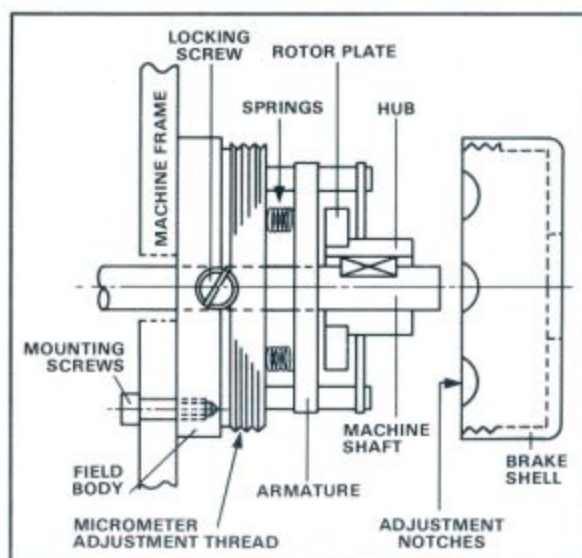

GENERAL SPECIFICATION Model FS 100/1

BRAKING TORQUES:

Static Holding Torque
Dynamic Braking Torque

Nm	kg cm	lb ins
17.5	180	155
13	135	116

Average Brake Disengagement time 40 m secs
Average Brake Engagement time 25 m secs
Weight 2.1 kg

Standard Coil Voltage 24 DC
Disengage Current (Continuous rated at 20°C) 0.6 amp
Electrical Power Consumption at 24 volts 14 watts
Coil Resistance (20°C) 40 ohms

Other models in the FS/1 series of fail safe brakes are available from 60 to 140mm diameters having braking torques 2-30 Nm.

Clark Electric Clutch also produces a complete range of electromagnetically engaged clutches and brakes from 25 to 200mm diameter with all associated power supply units and controls.

INSTALLATION DIMENSIONS

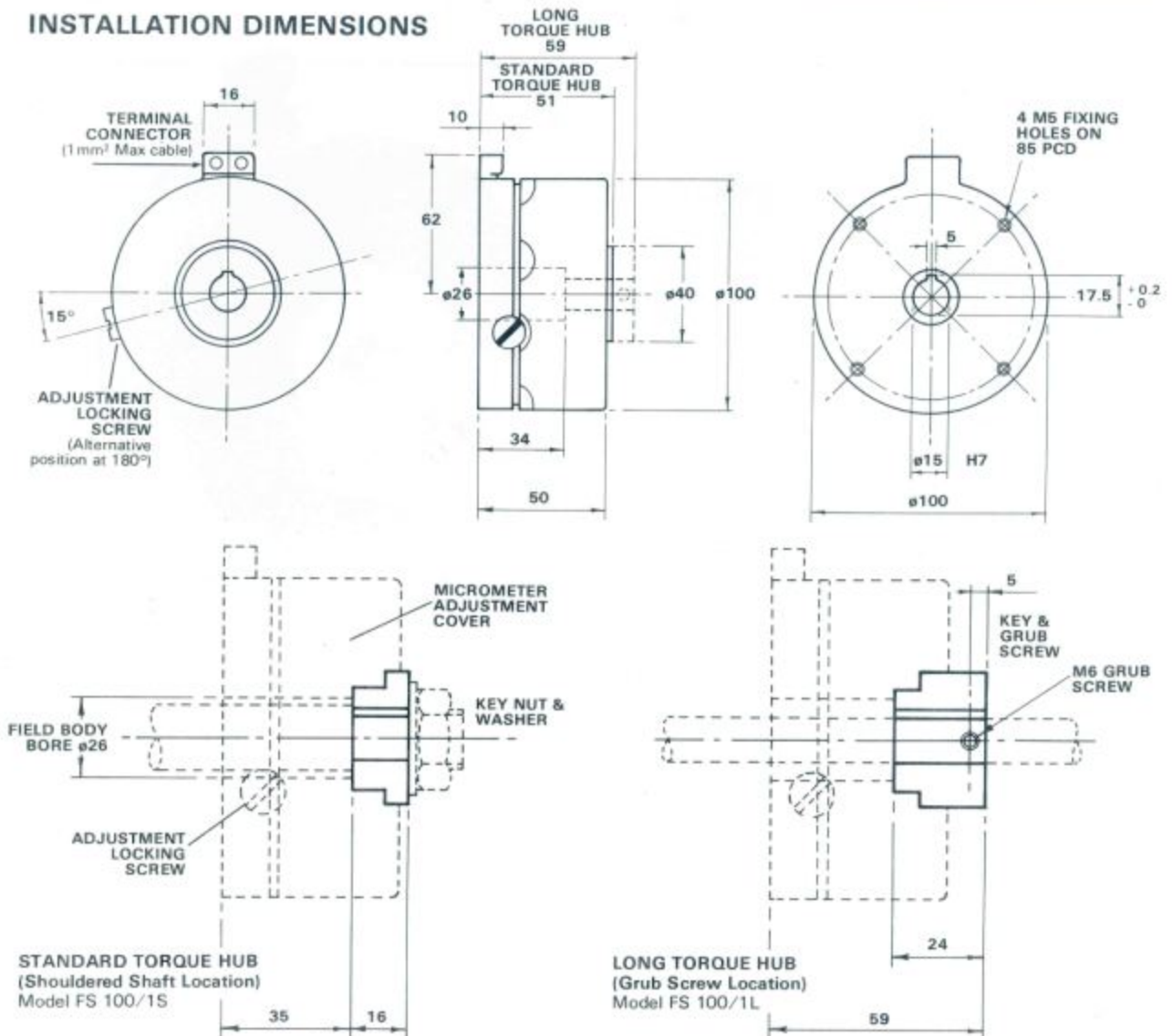

CLARK ELECTRIC CLUTCH AND CONTROLS Ltd

28 Victory Park, Trident Close, Medway City Estate, Rochester, Kent, ME2 4ER
Tel.: +44 (0)1634 297408 Fax.: +44 (0)1634 739136 e-mail: sales@clarkelectric.co.uk