

ALL
BRITISH
COMPANY

EXTENDED-HUB ELECTROMAGNETIC CLUTCHES

FOR PULLEY, CHAINWHEEL,
SPUR GEAR OR FLEXIBLE COUPLING

DATA
SHEET
SIZE
BM400EH

MAXIMUM STATIC TORQUE 23 Nm. (16 lbs. ft.)

Will transmit available torque of 1.1 Kw motor at 1440 r.p.m. with 2.5 times overload factor.

EXTENDED HUB CLUTCHES

Advantages

- Through shaft mounting for simple assembly.
- Clark Clutches are self-adjusting throughout their life.
- Will operate up to 60 times a minute where load inertia permits.
- Softstart facility available where used with Clark Silkstart Acceleration Controller.
- Lower power device 0.7 amp at 24 volt.

Extended Hub Clutches are designed for use where a remotely controlled drive is required to or from a shaft via a clutch and pulley etc. The Clutches are fitted with oil reservoir sleeve bearings contained within the steel keywayed hub to which the pulley etc. may be secured. When the Clutch is switched off, the hub idles on the shaft. When the Clutch is switched on, the hub is locked to the shaft.



Typical use of BM400EH Clutch :

Input drive may be to shaft or hub.

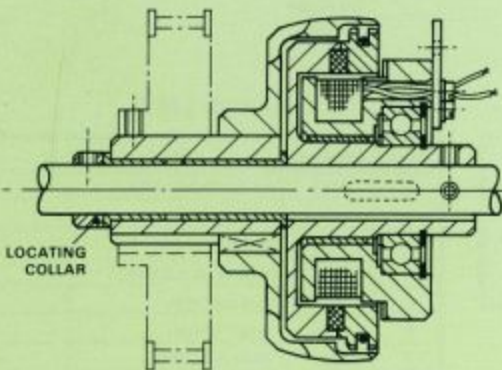

(a) with a pulley fitted.

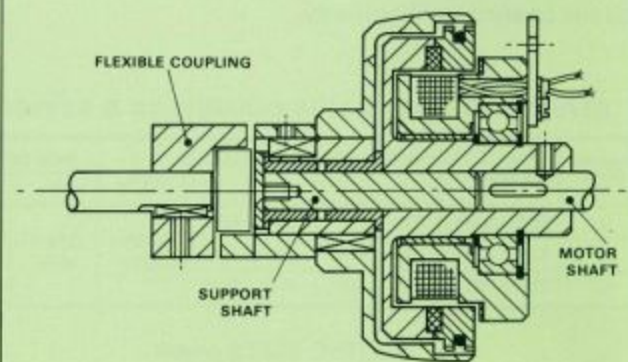

(b) with a flexible coupling fitted for an in-line coupling between two shafts where precise shaft alignment cannot be guaranteed.

See BM400 Clutch Data Sheet for full specification.

Bedding In

Where it is known that the Clutch and Brake are to be used on low speed applications, the unit may be supplied bedded-in in order that full torque will be available after a few operations.

On fast speed applications, the units will develop full torque after a few operations.

DATA SHEET
SIZE
BM400EH

EXTENDED-HUB ELECTROMAGNETIC CLUTCHES

FOR PULLEY, CHAINWHEEL,
SPUR GEAR OR FLEXIBLE COUPLING

ALL
BRITISH
COMPANY

Type BM400EH (incorporating bearing mounted Field Spool)

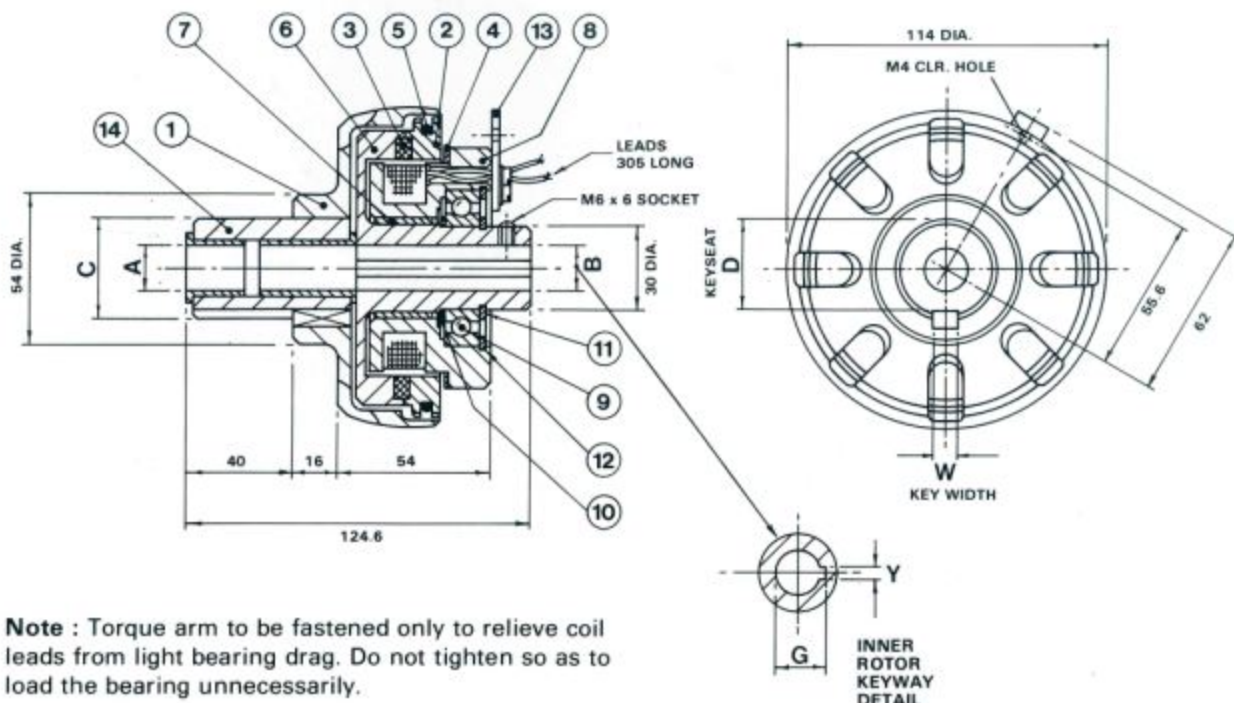

Note : Torque arm to be fastened only to relieve coil leads from light bearing drag. Do not tighten so as to load the bearing unnecessarily.

STANDARD BORES, HUB DIAMETERS & KEYWAYS

BEARING BORE A DIA.	B DIA.	INNER ROTOR KEYWAY		HUB DIA. C	HUB KEYWAY	
		Y	G		W	D
1/2"	.500"/.501"	.125"/.126"	.561"/.567"	1.3750"/1.3747"	.374"/.375"	1.223"/1.218"
5/8"	.625"/.626"	.188"/.189"	.714"/.720"			
3/4"	.750"/.751"	.188"/.189"	.838"/.844"			

METRIC SIZES (mm)

BEARING BORE A DIA.	B DIA.	INNER ROTOR KEYWAY		HUB DIA. C	HUB KEYWAY	
		Y	G		W	D
12	12.00/12.03	4.00/4.02	13.83/13.93	35.000/ 34.992	10.000/ 9.964	31.50/ 31.40
14	14.00/14.03		16.33/16.43			
15	15.00/15.03	5.00/5.02	17.33/17.43			
16	16.00/16.03		18.33/18.43			
19	19.00/19.03		21.83/21.93			
20	20.00/20.03	6.00/6.02	22.83/22.93			

PARTS LIST

ITEM	PART No.	TITLE
1	3163	EH OUTER MEMBER
2	4073	DRIVE RING
3	4086	FRICTION LINING
4	565	MAGNETIC INSULATOR
5	733	CUSHION RING
6	4786	INNER ROTOR
7	2081	SLEEVE BEARING
8	4592	BM FIELD SPOOL ASSY
9		BALL BEARING 6006 2RS
10		ABUTMENT CIRCLIP (External) 30mm
11		CIRCLIP (External) 30mm
12		CIRCLIP (Internal) 55mm
13	3157	TORQUE ARM
14	4135	EH SLEEVE & BEARING SUB-ASSY.

CLARK ELECTRIC CLUTCH AND CONTROLS Ltd

28 Victory Park, Trident Close, Medway City Estate, Rochester, Kent, ME2 4ER

Tel.: +44 (0)1634 297408 Fax.: +44 (0)1634 739136 e-mail: sales@clarkelectric.co.uk