

ALL
BRITISH
COMPANY

**EXTENDED-HUB
ELECTROMAGNETIC
CLUTCHES**
FOR PULLEY, CHAINWHEEL,
SPUR GEAR OR FLEXIBLE COUPLING

DATA
SHEET

SIZE
BM175EH

MAXIMUM STATIC TORQUE 1.1 Nm. (10 lb. ins.)

EXTENDED HUB CLUTCHES

Advantages

- Simple to fit - slide clutch onto shaft, fit key and lock collars.
- Through shaft mounting avoids need to align shafts.
- Clark Clutches are self-adjusting throughout their life.
- Will operate small mechanism several times a second when used with boost supply.
- Low power device 0.25 amp at 24 volt.

Extended Hub Clutches are designed for use where a remotely controlled drive is required to or from a shaft via a clutch and pulley etc. The Clutches are fitted with oil reservoir sleeve bearings contained within the steel keywayed hub to which the pulley etc. may be secured. When the Clutch is switched off, the hub idles on the shaft. When the Clutch is switched on, the hub is locked to the shaft.

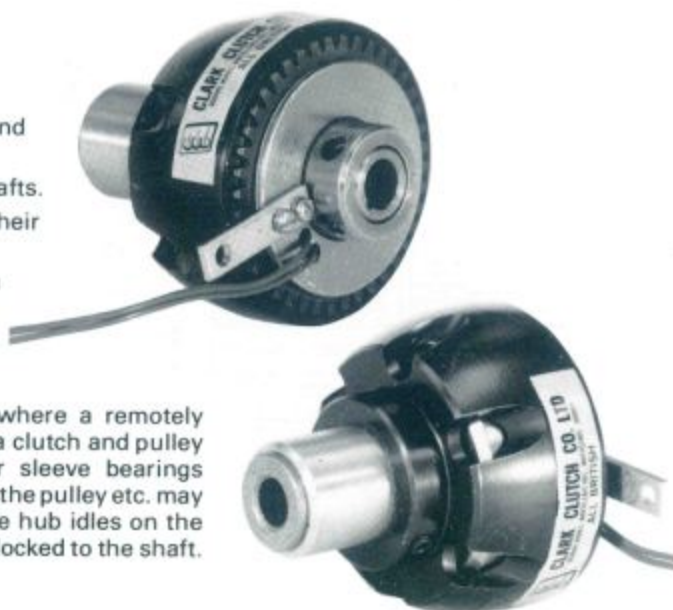

Typical use of BM175EH Clutch :

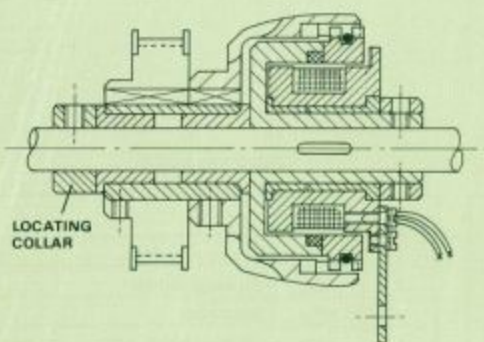

(a) clutch mounted on through shaft with pulley fitted to hub.

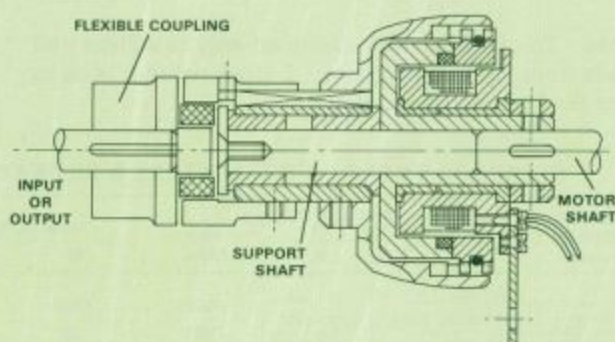

(b) with a flexible coupling fitted for an in-line coupling between two shafts where precise shaft alignment cannot be guaranteed.

See BM175 Clutch Data Sheet for full specification.

Bedding In

Where it is known that the Clutch and Brake are to be used on low speed applications, the unit may be supplied bedded-in in order that full torque will be available after a few operations.

On fast speed applications, the units will develop full torque after a few operations.

DATA SHEET

SIZE
BM175EH

EXTENDED-HUB ELECTROMAGNETIC

CLUTCHES

FOR PULLEY, CHAINWHEEL,
SPUR GEAR OR FLEXIBLE COUPLING

ALL
BRITISH
COMPANY

Type BM175EH

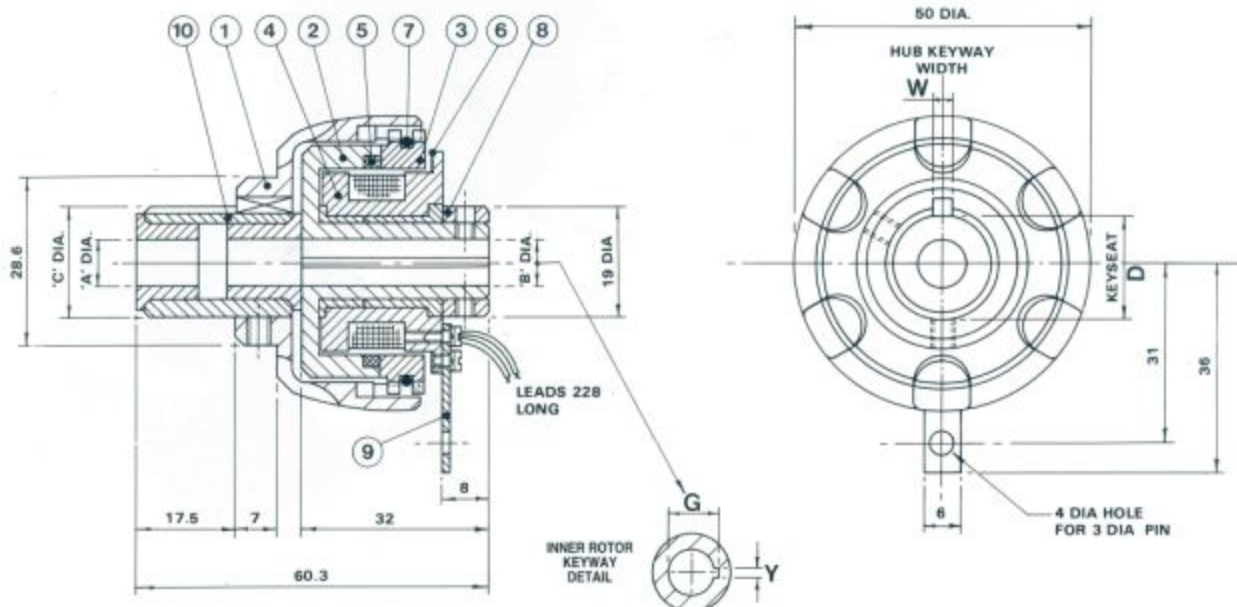

Note : Torque arm to be fastened only to relieve coil leads from light bearing drag. Do not tighten so as to load the bearing unnecessarily.

STANDARD BORES, HUB DIAMETERS & KEYWAYS

BEARING BORE A DIA.	B DIA	INNER ROTOR KEYWAY		HUB DIA.C	HUB KEYWAY	
		Y	G		W	D
1/4"	.250"/.251"			.7500"/.7495"	.124"/.125"	.677"/.671"
5/16"	.3125"/.3135"	-125	-372"/-378"			
3/8"	.375"/.376"		-409"/-415"			

METRIC SIZES (mm)

BEARING BORE A DIA.	B DIA	INNER ROTOR KEYWAY		HUB DIA C	HUB KEYWAY	
		Y	G		W	D
6	6.00/6.03			20.00/19.99	4.00/3.97	17.5/17.4
8	8.00/8.03	2.00/1.99	9.03/9.13			
9	9.00/9.03	3.00/3.02	10.43/10.53			

PARTS LIST

ITEM	PART No.	TITLE
1	3477	EH OUTER MEMBER
2	2065	BM INNER ROTOR
3	5254	DRIVE RING
4	3734	BM FIELD SPOOL ASSY.
5	5265	FRICTION LINING
6	4854	MAGNETIC INSULATOR
7	735	CUSHION RING
8	2066	COLLAR
9	2067	TORQUE ARM
10	4127	EH SLEEVE AND BEARING SUB ASSY.

CLARK ELECTRIC CLUTCH AND CONTROLS Ltd

28 Victory Park, Trident Close, Medway City Estate, Rochester, Kent, ME2 4ER

Tel.: +44 (0)1634 297408 Fax.: +44 (0)1634 739136 e-mail: sales@clarkelectric.co.uk