

CLARK ELECTRIC CLUTCH

BM-EH TYPE CLUTCH INSTALLATION DATA 175 250 & 400

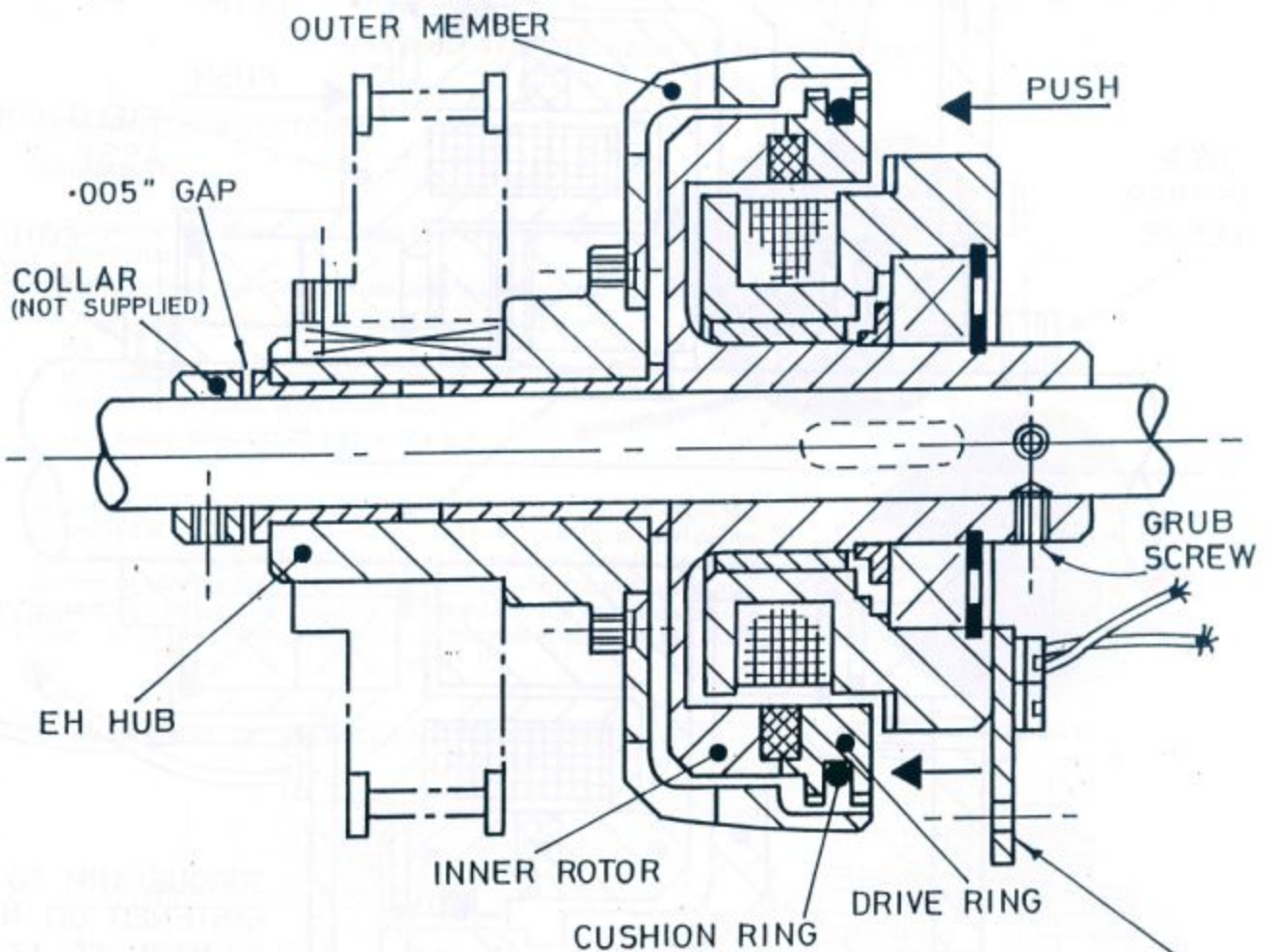

TORQUE ARM TO BE RESTRAINED DO NOT TIGHTEN SO AS TO LOAD THE BEARINGS.

FOR THIS OPERATION

THE CLUTCH MAY NOT "PULL IN" WHEN THE COIL IS FIRST ENERGISED. WITH THE INPUT DRIVE STATIC AND THE FULL 24VOLT DC SWITCHED ON, THE DRIVE RING SHOULD BE EASED TOWARD THE INNER ROTOR UNTIL IT PULLS IN.

CLARK **ELECTRIC CLUTCH**

BM-EH TYPE CLUTCH INSTALLATION DATA 600 & 800

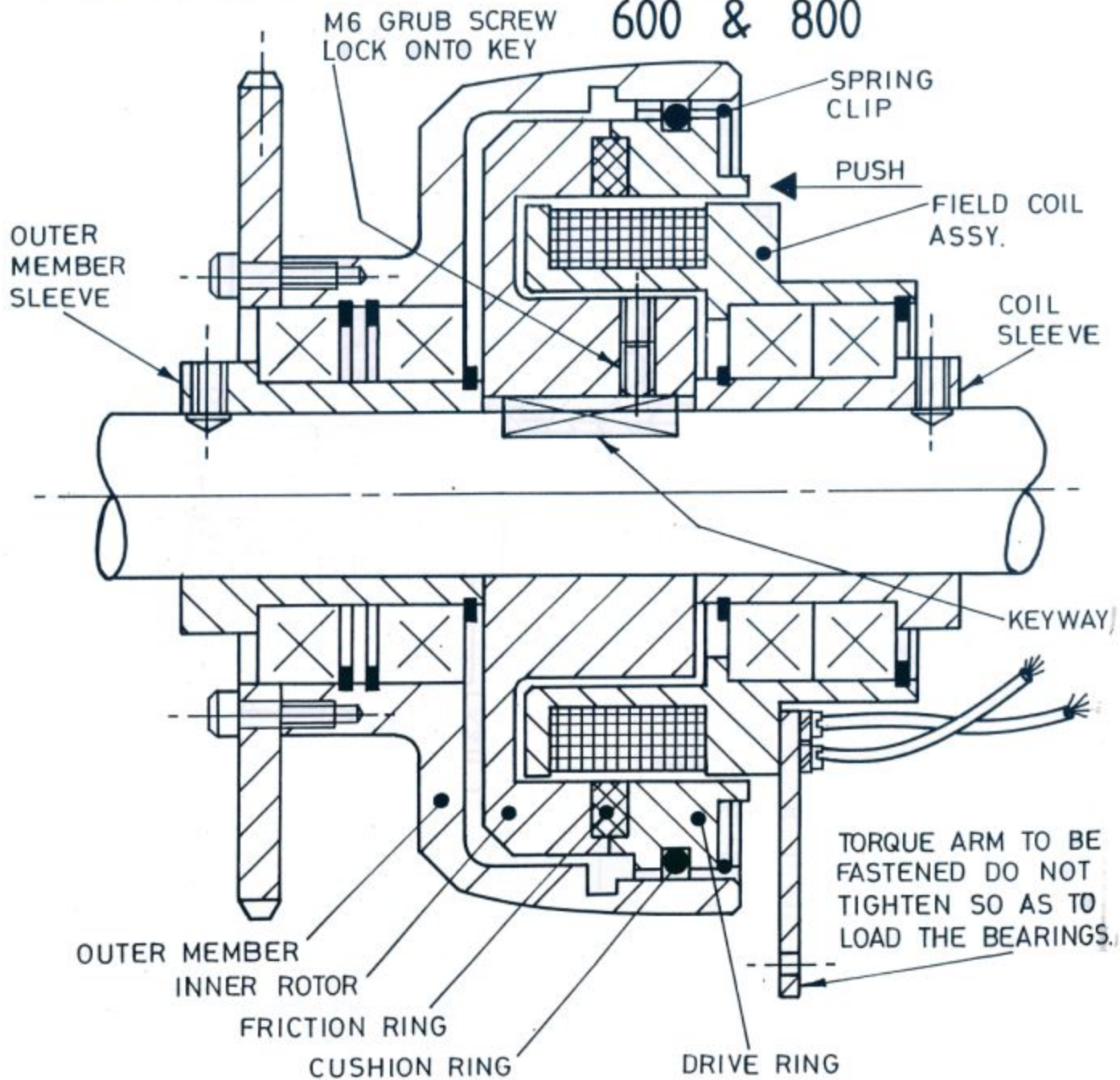

THE CLUTCH MAY NOT "PULL IN" WHEN THE COIL IS FIRST ENERGISED. WITH THE INPUT DRIVE STATIC AND THE FULL 24 VOLT DC SWITCHED ON, THE DRIVE RING SHOULD BE EASED TOWARD THE INNER ROTOR UNTIL IT PULLS IN.