

CLARK ELECTRIC CLUTCH

CLARK ELECTRIC CLUTCH & CONTROLS Ltd.,

BM TYPE CLUTCH INSTALLATION DATA BM 175, 250 & 400

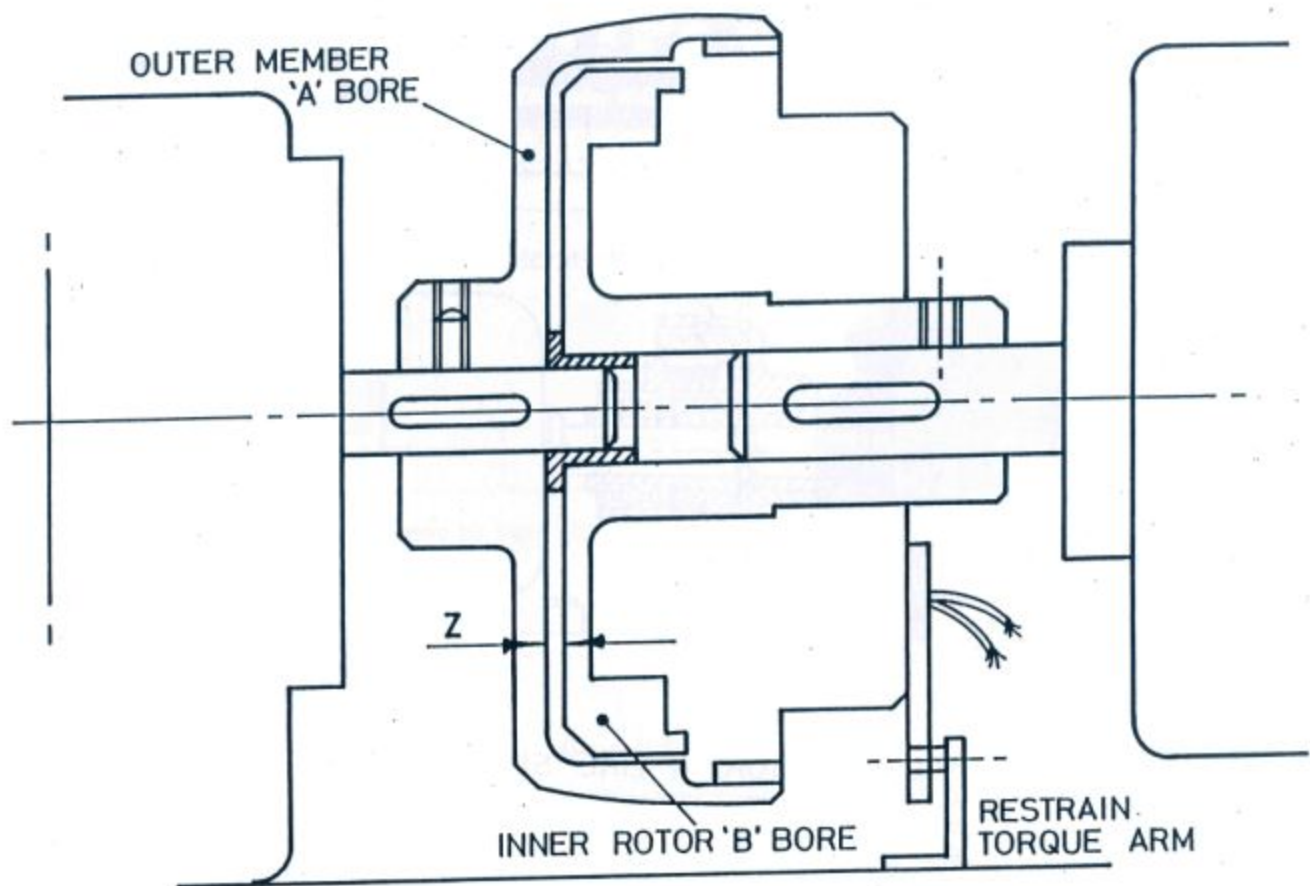

TO ASSIST THE ALIGNMENT OF THE SHAFTS BEING COUPLED WITH A BM TYPE CLUTCH USE A PILOT BEARING IN THE END OF THE INNER ROTOR.

1 IF BOTH BORES ARE THE SAME DIAMETER THE INNER ROTOR MAY BE COUNTER BORED (MAX. DIA. SEE TABLE) TO ACCOMMODATE THE BUSH.

2 USE FLANGED BEARING SO THAT THE FLANGE SETS THE GAP REQUIRED BETWEEN OUTER MEMBER AND INNER ROTOR.

MAX. COUNTER BORE DIA.	
BM 175	10mm
BM 250	14mm
BM 400	24mm

Size	Gap	'Z'
1.75		1.6
2.50		1.6
4.00		2.4

Setting Up Alignment	Size	Total Indicated Reading
Parallel alignment between shafts should be within :	1.75	0.13 (.005")
	2.50	
	4.00	
Angular alignment between shafts	1.75	0.13 (.005") measured at 27 dia.
	2.50	0.13 (.005") measured at 45 dia.
	4.00	0.13 (.005") measured at 76 dia.

CLARK ELECTRIC CLUTCH

BM TYPE CLUTCH INSTALLATION DATA

BM 600 & 800 CLUTCHES BETWEEN TWO IN-LINE SHAFTS

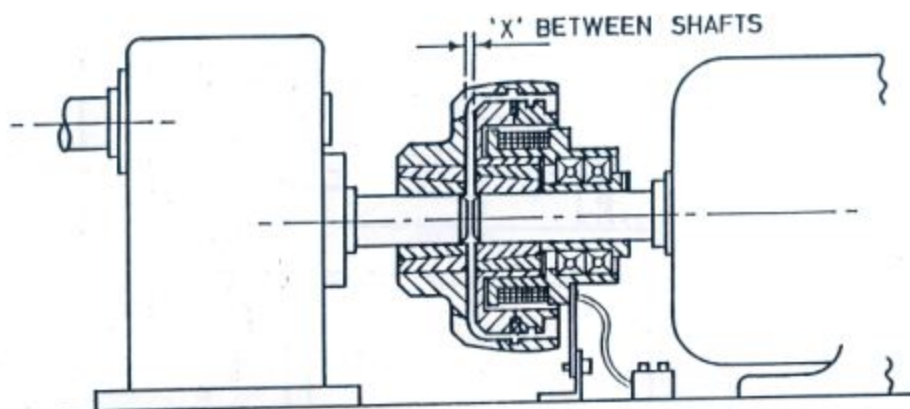

- 1 MOUNT MOTOR & GEARBOX (OR IN-LINE SHAFT) ON COMMON MACHINED BASE.
- 2 LINK SHAFTS WITH SOLID COUPLING & WHEN ALIGNMENT IS CORRECT PIN MOTOR, ETC., TO BASE.
- 3 REMOVE ONE UNIT & FIT THE CLUTCH. WHEN RE-ASSEMBLED THE SHAFT ALIGNMENT MUST BE CORRECT.
- 4 NEVER ATTEMPT TO FIT THE CLUTCH BETWEEN TWO SHAFTS THAT HAVE NOT BEEN CORRECTLY ALIGNED & PINNED.
- 5 WHERE ABOVE CONDITIONS CANNOT BE MET USE AN EH TYPE CLUTCH FITTED WITH A FLEXIBLE COUPLING.

Required shaft alignment accuracy	Size	Total Indicated Reading
Shaft parallel alignment to be within :	600 Clutch	.254 (.010")
	800 Clutch	.254 (.010")
Shaft angular alignment	600 Clutch	.762 (.030") measured at 76 radius
	800 Clutch	.889 (.035") measured at 101 radius

DIM. 'X'	CLUTCH
1/8"	BM 600
5/32"	BM 800